

# Modeling & Simulation (Computational Immunology)

**Steven H. Kleinstein**

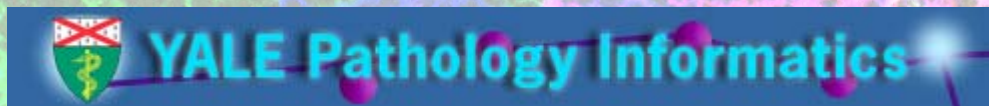

Department of Pathology  
Yale University School of Medicine

[steven.kleinstein@yale.edu](mailto:steven.kleinstein@yale.edu)

March 24, 2014

# What is a mathematical model?

Uses mathematical language to describe a system

A mathematical model consists of a collection of variables and rules governing their values.

Models are **based on assumptions** inspired by observing some real phenomena in the hope that the model behavior resembles the real behavior.

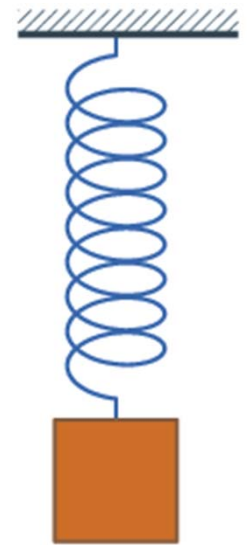

Mathematical modeling is process of constructing, testing, and improving mathematical models

# Advantages of the modeling approach in biology

“Essentially, all models are wrong, but some are useful.”  
-George Box, University of Wisconsin

- Concise summary of present knowledge of operation of a particular system
- Predict outcomes of modes of operation not easily studied experimentally in a living system
- Provide diagnostic tools to test theories about the site of suspected pathology or effect of drug treatment
- Clarify / simplify complex experimental data
- Suggest new experiments to advance understanding of a system

# Limitations of the modeling approach

“Essentially, all models are wrong, but some are useful.”  
-George Box, University of Wisconsin

- Models often require many simplifying assumptions
  - beware of garbage in, garbage out
- Validation of model predictions is essential
  - examination of behavior under known limiting conditions
  - experimental validation
  - limits of model can point out what we don't understand

# Modeling the immune response

If you want more information on the biology...

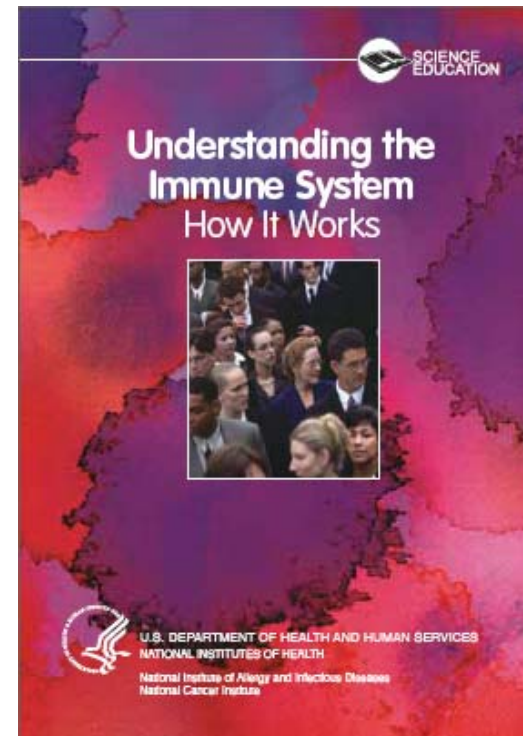
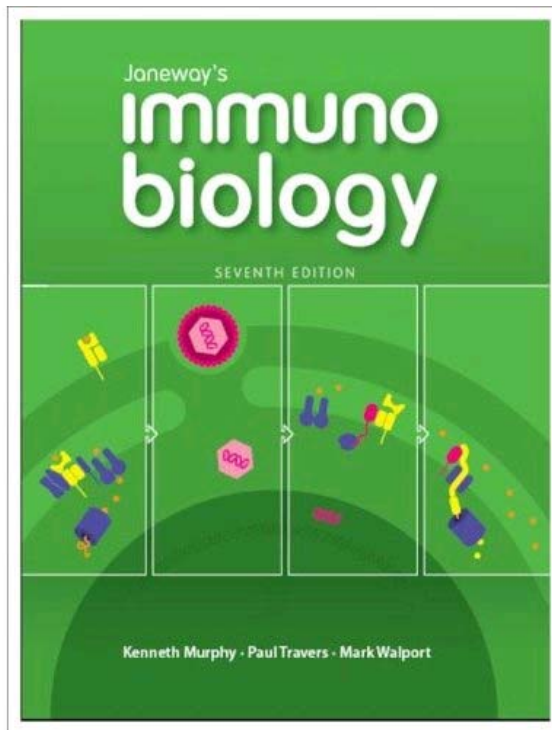

Janeway's Immunobiology

- or -

<http://www3.niaid.nih.gov/topics/immuneSystem>

# The Immune System

Science that began with Jenner in 1796

- A network of cells, tissues, and organs that work together to defend the body against attacks by “foreign” invaders (antigens).
  - Primarily microbes (germs)—tiny, infection-causing organisms such as bacteria, viruses, parasites, and fungi.
- Provides basis for vaccines (e.g., flu shot)
- But also implicated in disease:
  - Autoimmune (Lupus, MS, Rheumatoid Arthritis)
  - Respond to harmless foreign substance (ragweed pollen) produces allergy
  - Sepsis, Cancer
- Understanding will lead to better diagnostics & therapies

Organs of immune system = “lymphoid organs”, since home to lymphocytes (small white blood cells that are key players in the immune system)

# Why Model the Immune System?

Experiments provide only a static window onto the real dynamics of immunity

- Immune response involves the collective and coordinated response of  $\approx 10^{12}$  cells and molecules
- Spatially-distributed system
  - blood, lymph nodes, spleen, thymus, bone marrow, etc.
- Feedback loops and non-linear dynamics
- Experiments often require artificial constructs

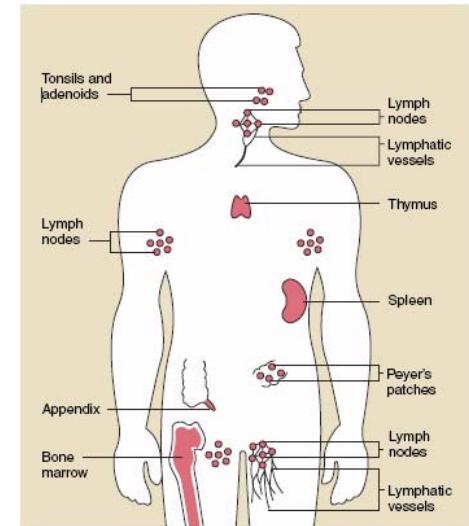

Models can help understand the source(s) of variability between experiments

# Increasing Impact of Computational Immunology

All journals now publish papers with significant computational components

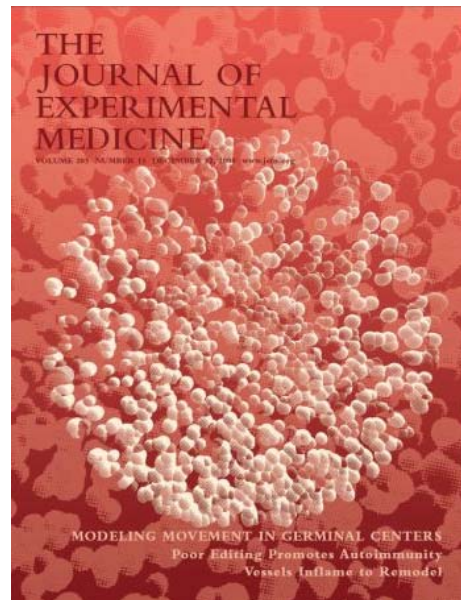
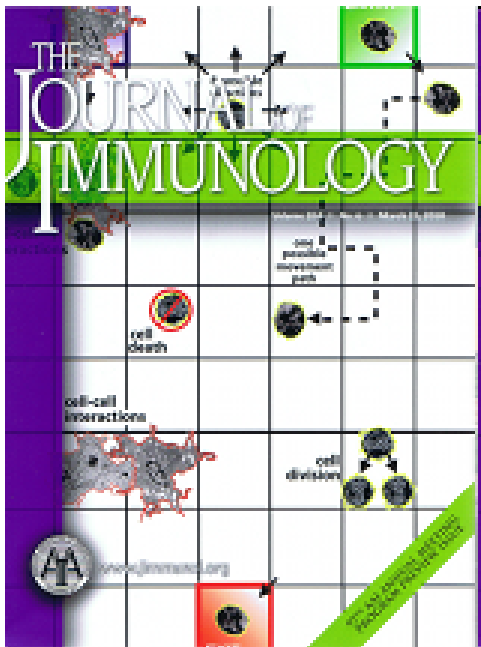

Summer School on  
Computational Immunology  
(June 9-13, 2014)



Award applications deadline:  
April 10

<http://www.niaid.nih.gov/about/organization/dait/Pages/modelingImmunity.aspx>



# Mechanistic modeling vs. curve fitting

Only mechanistically correct models extrapolate reliably

Gene transcriptionally activated by complex of three proteins, and one acts as scaffold

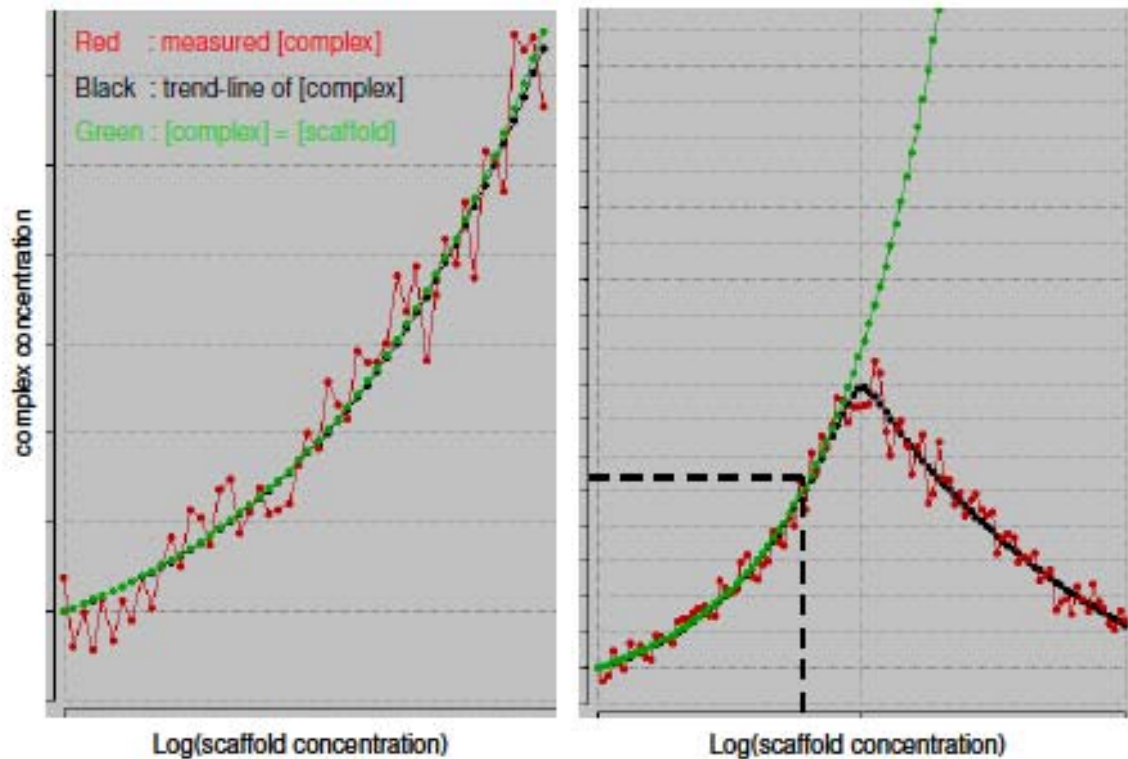
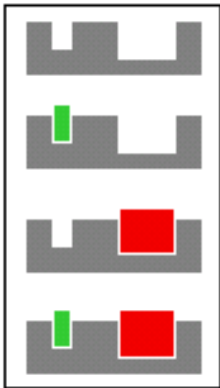

Figures from: Hamid Bolouri

**Interpolation** (i.e. within sample predictions) vs.  
**Extrapolation** (i.e. out of sample predictions, as in the right panel)

# Dynamic vs. Static modeling

A dynamic model accounts for the element of time, while a static model does not

Exponential growth of virus

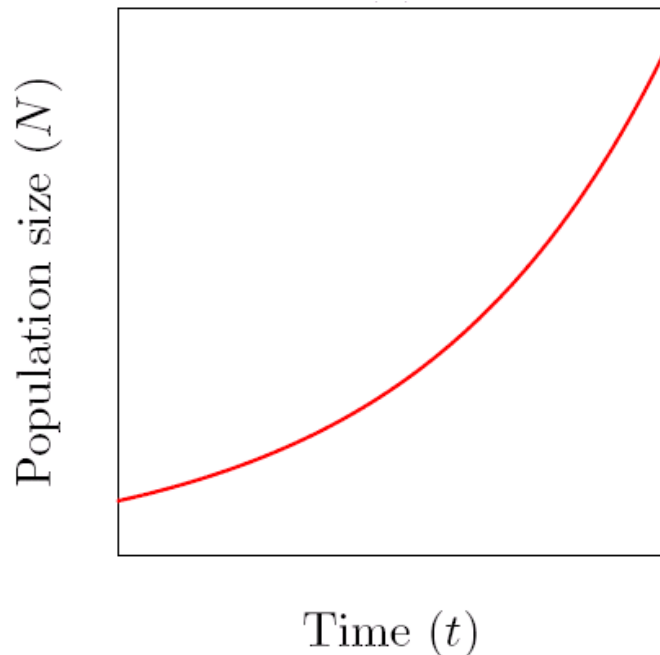

White blood cells produced by bone marrow

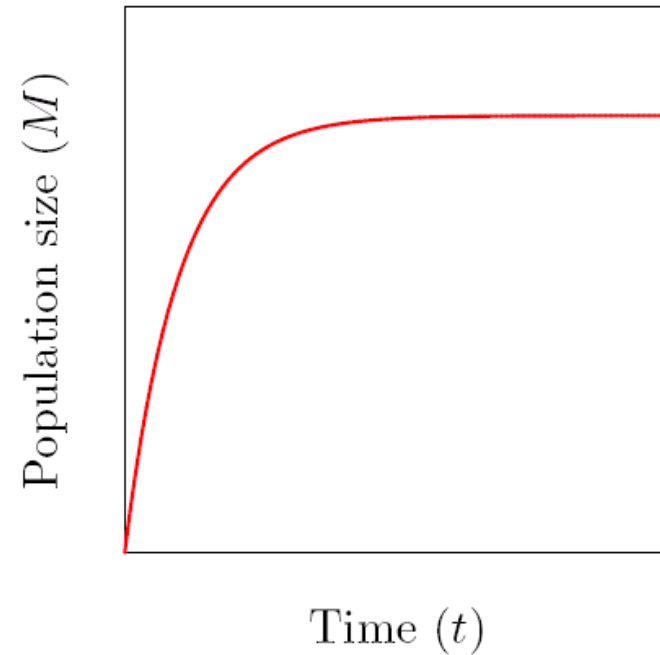

Dynamic equations can be simulated to study system behavior

# Types of Dynamic Models

Choosing the type of model is an important first step

- **Continuous**: time or state variables (often called ‘density’)
  - Ordinary differential equations
- **Discrete**: time or state variables
  - assume a small set of qualitative states e.g. active or inactive
  - changes in state are given by discrete (logical) rules
- **Deterministic**: no randomness is involved in the development of future states of the system
  - Given model structure, parameter values, and initial conditions, there is no variation in output
- **Stochastic**: the next state of is not fully determined by the previous state – probability is involved
  - can take into account the fluctuations in mRNA/protein/cell numbers and external noise

Spatial structure can also important

# Ordinary Differential Equations (ODEs)

Continuous and Deterministic

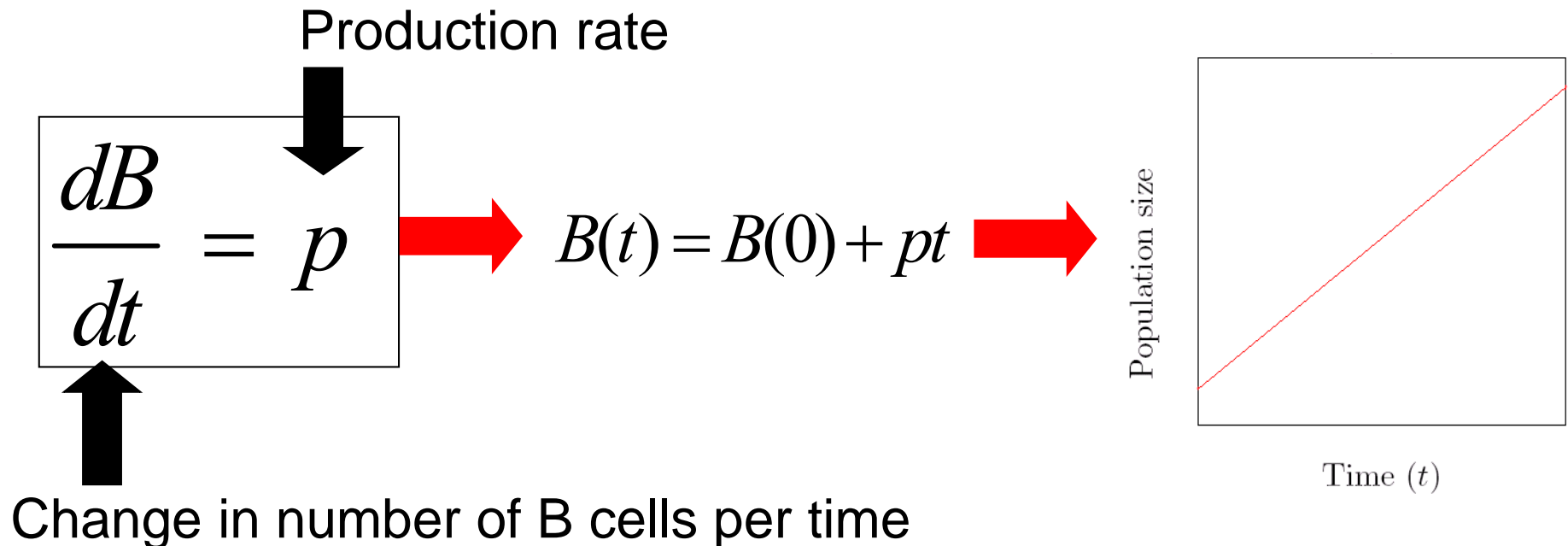

$$\frac{dB}{dt} = \lim_{t \rightarrow 0} \frac{B(t + \Delta t) - B(t)}{\Delta t}$$

Most models used in practice not solvable → **simulate**

# Exponential growth (and decay)

Continuous and Deterministic

$$\frac{dN}{dt} = rN$$

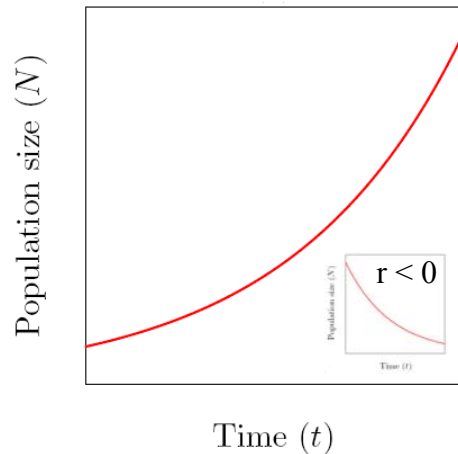

Human Population

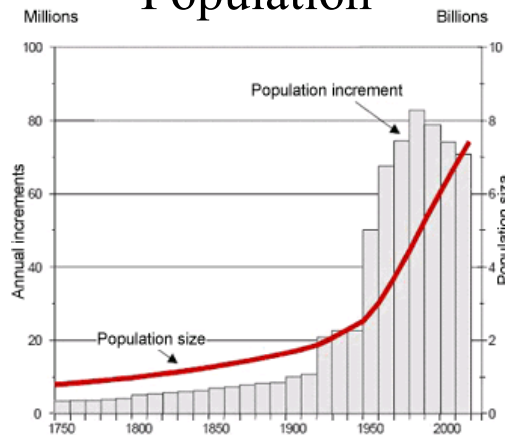

How long for population to double?

$$2N(0) = N(0)e^{rt}$$

$$\ln 2 = rt$$

$$t = \ln[2]/r$$

$$N(t) = N(0)e^{rt}$$

**Doubling time:** time for population to reach 2x initial value

**Half-life:** time for population to reach 50% of initial value

# Steady-state

Population sizes remain constant at steady-state

## Red Blood Cell production



$$\frac{dR}{dt} = p - cR$$

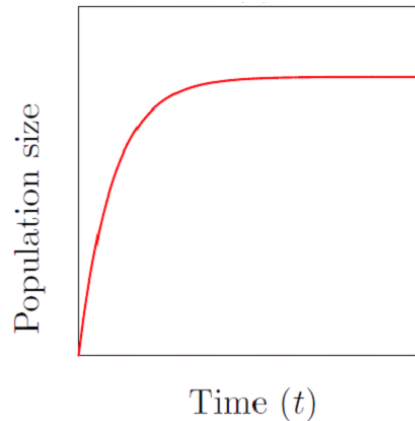

**How many cells  
at steady-state?**

$$0 = p - cR$$
$$\downarrow$$
$$R = p/c$$

Solve for steady state by setting derivatives equal to zero

# Density dependence

Birth (or death) rate may depend on population size

$$\frac{dN}{dt} = bN - dN$$

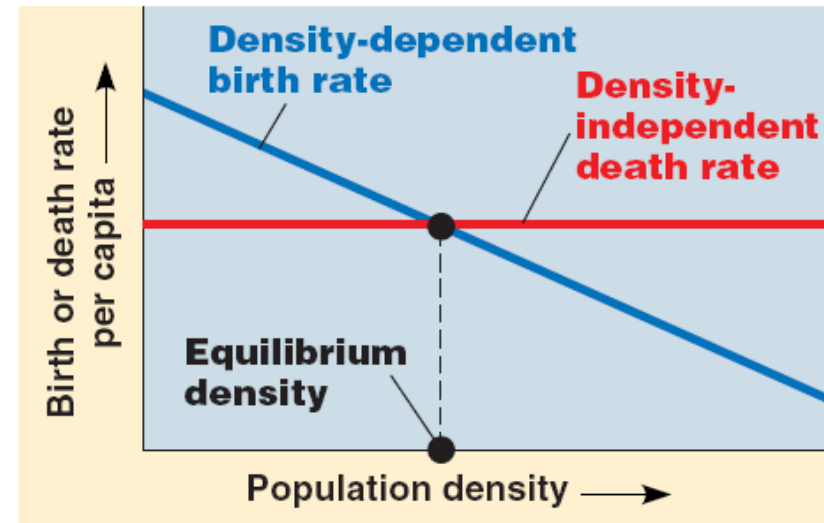

$$N = K \left( 1 - \frac{d}{b} \right)$$

**Stable steady-state**: small perturbations return to same state

# Logistic Model (S-shaped curve)

Includes density-dependent birth and death ( $r = b - d$ )

$$\frac{dN}{dt} = rN \left( 1 - \frac{N}{K} \right)$$

Initial stage of growth is approximately exponential; growth slows as saturation begins, and then stops at maturity.

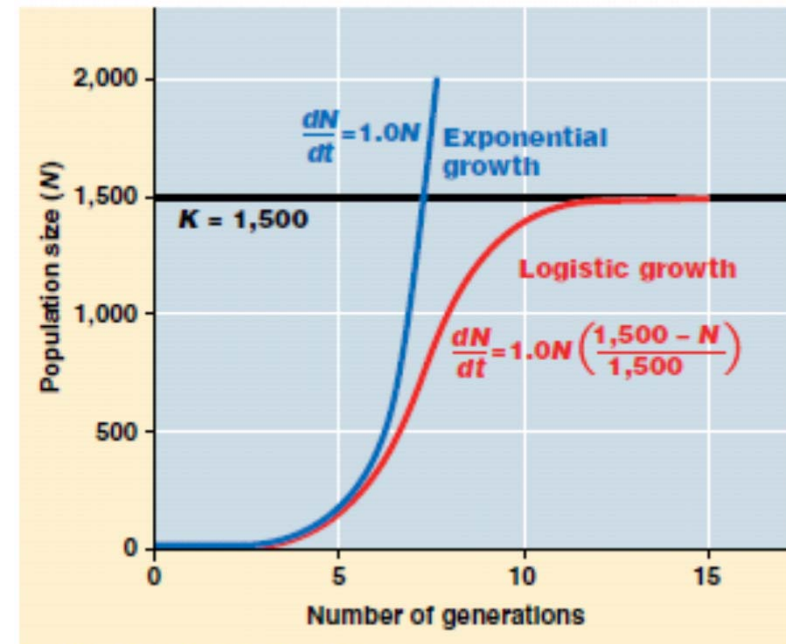

Copyright © Pearson Education, Inc., publishing as Benjamin Cummings.

Is this a “model” if can’t explain why birth/death rate  $r \sim N/K$ ?  
*phenomenological model*

Carrying capacity (K): population size that can be sustained indefinitely



# Modeling Interactions

**Law of mass action** (also called the mean-field assumption):

Entities encounter each other according to their relative abundance across space -- the rate of an elementary reaction is proportional to product of concentrations of participating entities

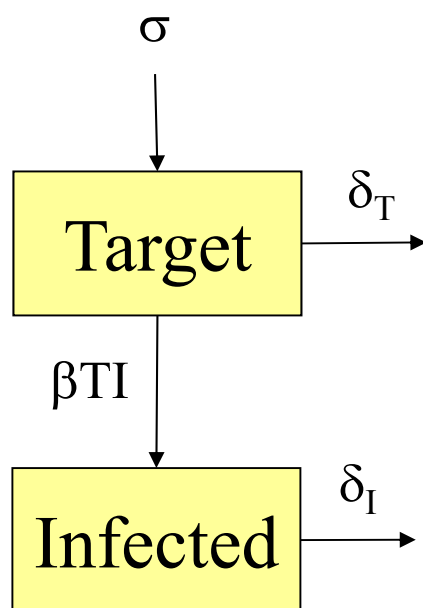

Target cells (T) become infected cells (I)

Target

$$\frac{dT}{dt} = \sigma - \delta_T T - \beta TI$$

Infected

$$\frac{dI}{dt} = \beta TI - \delta_I I$$

Other approaches are needed to account for spatial structure

# Phase Plane Analysis

Nullclines plot where derivatives are zero (cross at steady-state)

Target  $\frac{dT}{dt} = \sigma - \delta_T T - \beta T I$

Infected  $\frac{dI}{dt} = \beta T I - \delta_I I$

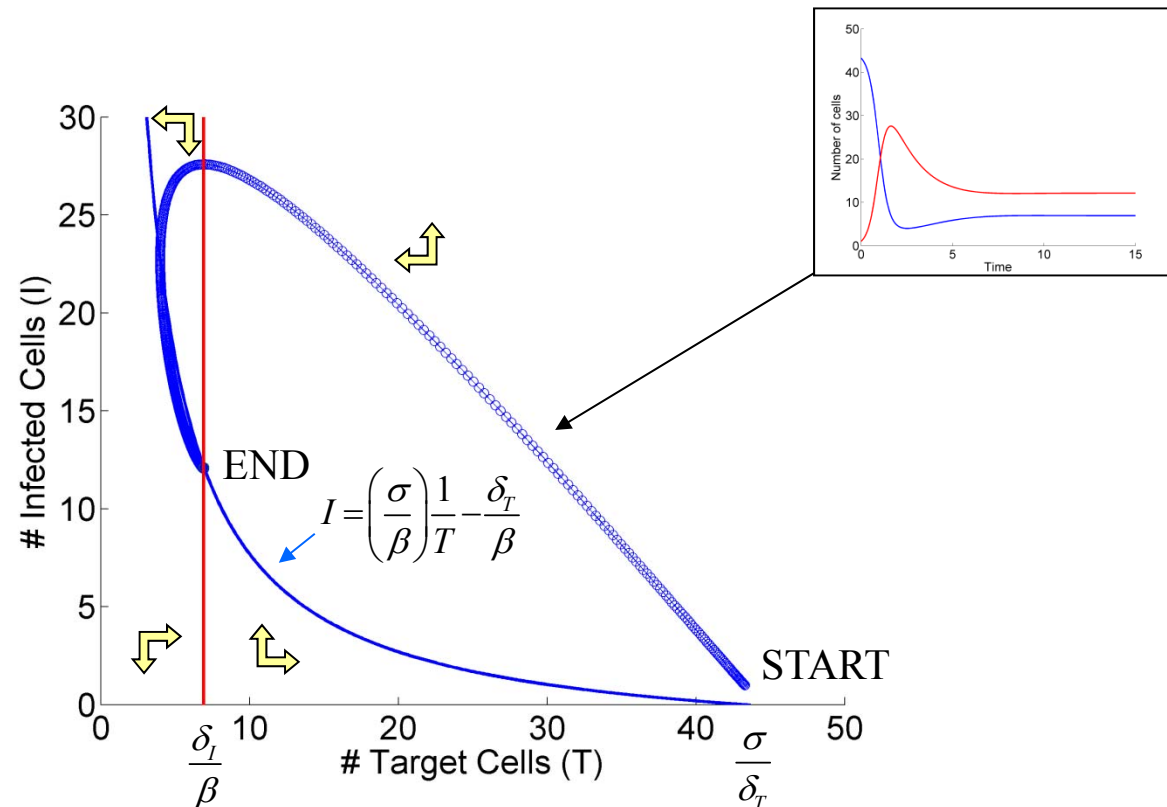

Phase portraits plot typical trajectories in the state space

# The Modeling Process

Starts with a specific scientific question

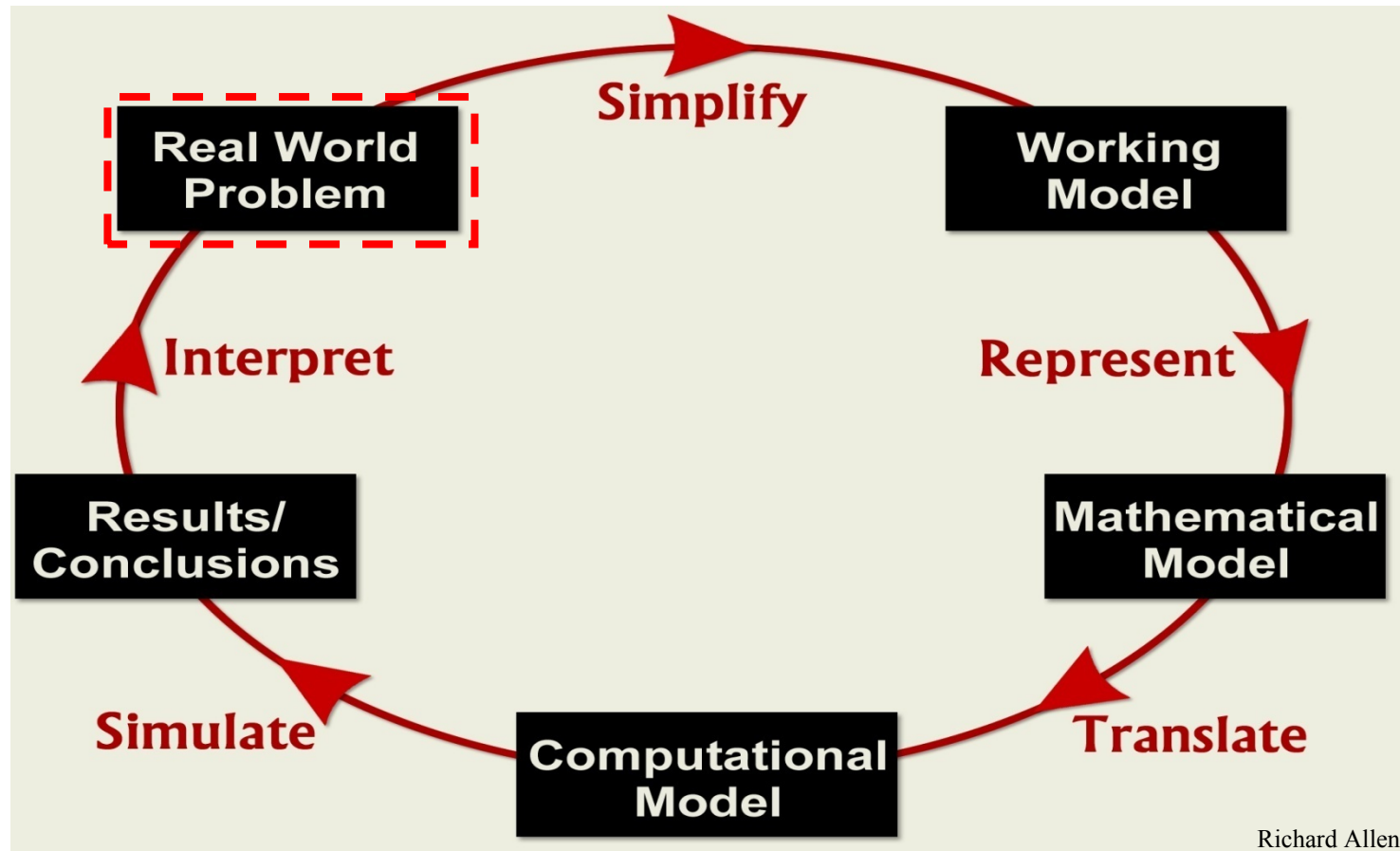

Model should produce predictions that suggest new experiments

# B cells “recognize” antigens thorough antibody receptor

**First phase of diversification occurs in bone marrow while cell is maturing**

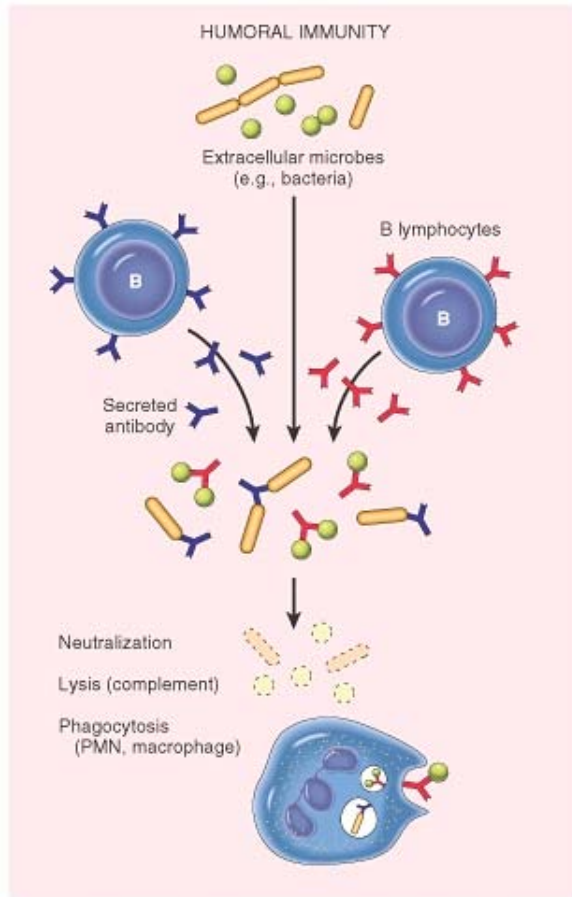

Copyright © 2002, Elsevier Science (USA). All rights reserved.

Rearrangement generates diverse receptors:

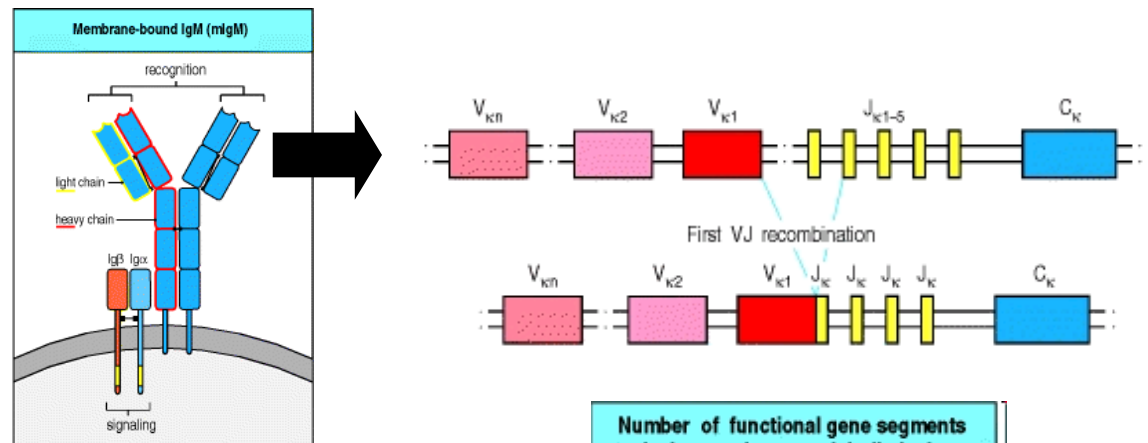

Number of functional gene segments in human immunoglobulin loci			
Segment	Light chains		Heavy chain
	$\kappa$	$\lambda$	H
Variable (V)	40	30	65
Diversity (D)	0	0	27
Joining (J)	5	4	6

**Second phase of diversification (by somatic hypermutation) follows activation**

# The Modeling Process: V(D)J Recombination

How are VJ segments chosen to generate an Ig light chain?

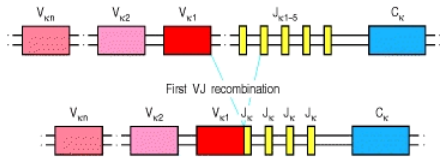

Hypothesis: VJ chosen randomly with equal probability

Observed V usage

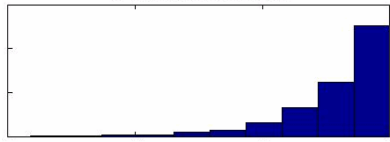

Predicted V usage

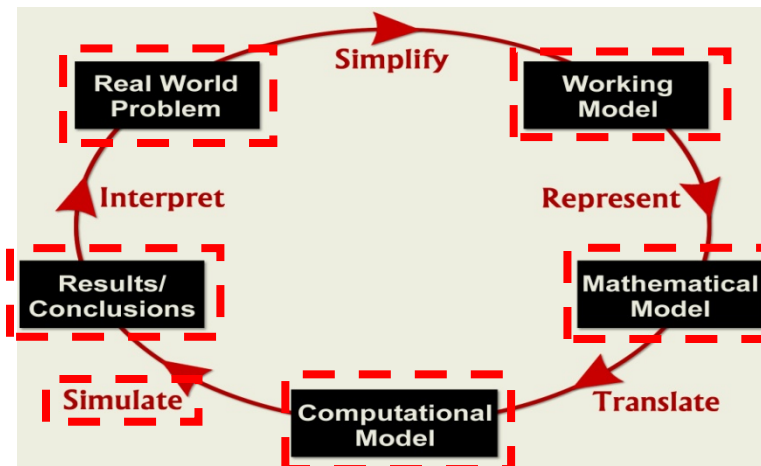
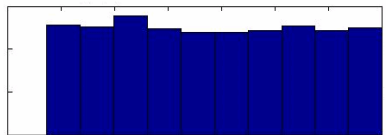

$$\Pr[V_n] = 1/N; P[J_m] = 1/M$$

$$\text{randInteger}(N) = \text{floor}(N * \text{rand}()) + 1$$

Model should produce predictions that suggest new experiments

# The Modeling Process: V(D)J Recombination

## Extend rearrangement model to cover different alleles

*seminars in IMMUNOLOGY*, Vol. 14, 2002; pp. 169-190  
doi:10.1016/S1044-5323(02)00041-6, available online at <http://www.idealibrary.com on> 

### Analysis of B cell receptor production and rearrangement Part I. Light chain rearrangement<sup>☆</sup>

Yoram Louzoun<sup>a,\*</sup>, Tzivya Friedman<sup>a</sup>, Eline Luning Prak<sup>b</sup>, Sam Litwin<sup>c</sup>  
and Martin Weigert<sup>a</sup>

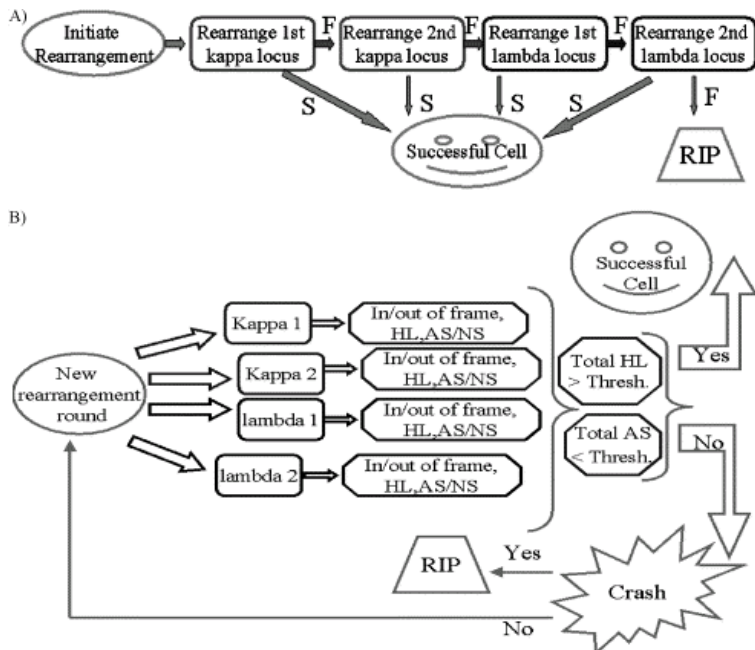

A probabilistic model of allelic exclusion fails to explain the status of receptor genes and the receptor phenotype of most B cells... we have revived the purely probabilistic approach in a model that now includes receptor editing and allows for some multi-receptor B cells. We find that this model can explain the observed properties of B cells when the frequency of self-reactive B cells is high...

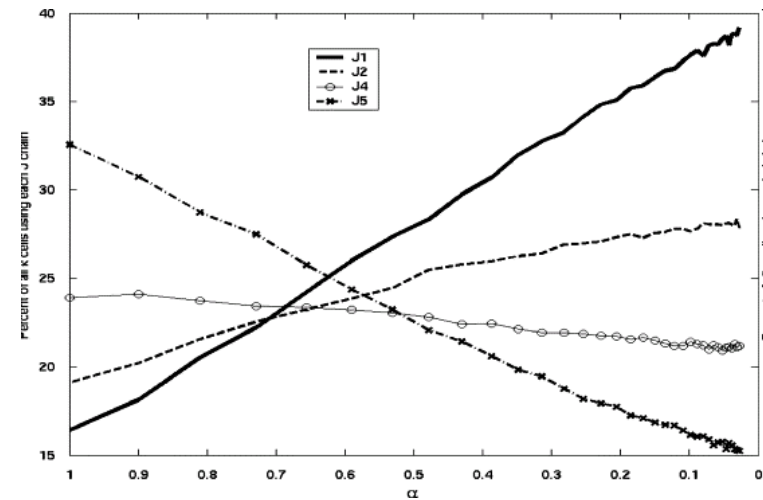

Alpha reflects degree of sequentiality for  $J_k$  rearrangement.

Revised model of rearrangement suggest new experiments

# Things to ask before any modeling study

Frank Tobin (2009): Modeling is Powerful BUT Has Far to Go

**Bio-IT**World.com

1. Why do you want to do modeling?
2. How will you know if you succeed?
3. What will you do with the model once you have it? For what decisions will it be used or what confirmatory experiments will get performed?

Beware motivation: “We want to create a model of process X...”

# Forward Modeling

- Detailed mathematical model designed to incorporate a desired level of anatomic or physiologic features
  - Can have arbitrary complexity as desired
  - Parameter values often obtained from published literature
  - Ex: tissue structure formation, cell signaling networks
- Used for simulating realistic experimental data under precisely defined conditions to test hypotheses *in silico*
- Can help design better experiments and reduce animal use
- Generally too complicated for fitting to experimental data

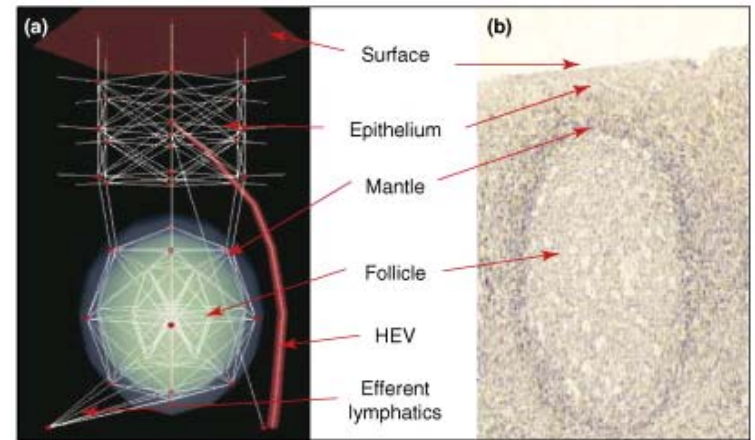

(Thorley-Lawson et al, 2008)

Allows generation of synthetic data sets with prescribed noise characteristics (Monte Carlo simulation) for evaluating parameters obtained by inverse modeling



# Inverse Model

- A mathematical model designed to fit experimental data so as to explicitly quantify physical or physiological parameters of interest
- Values of model elements are obtained using parameter estimation techniques aimed at providing a “best fit” to the data
- Generally involves an iterative process to minimize the average difference between the model and the data
- Evaluating the quality of an inverse model involves a combination of established mathematical techniques as well as intuition and creative insight

“Essentially, all models are wrong,  
but some are useful.”

-George Box, University of Wisconsin